

STANDARD EXECUTIONS

- **GN 119-DK:** stator and rotor in chrome-plated zinc alloy, latch cam, screw, washer, spring washer and nut M22x1.5 in zinc-plated steel, distance element in aluminium.

Triangular groove for key.

- **GN 119-DK-NI:** stator and rotor in AISI 303 stainless steel, latch cam in AISI 304L stainless steel, screw, washer, spring washer and nut M22x1.5 in stainless steel, distance element in AISI 303 stainless steel.

- **GN 119-VDE:** same as above but with two-wing groove for key.

Triangular groove for key.

- **GN 119-VDE-NI:** same as above but with two-wing groove for key.

PACKING RING

NBR synthetic rubber.

KEYS (TO BE ORDERED SEPARATELY)

Die-cast zinc alloy with epoxy resin coating, RAL 9005 black colour, matte finish.

- With triangular groove (code GN.38701 GN 119.2-86-DK7).

- With two-wing groove (code GN.38711 GN 119.2-86-VDE5-SW).

FEATURES AND APPLICATIONS

GN 119-NI cam latches have a pulling-in range of 10mm. Locking is achieved by turning the knob/key clockwise.

The internal O-ring prevents the ingress of water.

SPECIAL EXECUTIONS AND ACCESSORIES

- Latches with recessed key with square mark (GN 119-VK-NI).

- Sheet metal puncher GN 123 (see page 1557).

ASSEMBLY INSTRUCTIONS

1. Drill a hole in the door as per the drilling template drawing with the axis at a distance of 23 mm from the door frame.
2. Insert frontally the latch body in the hole of the door and screw on the threaded nut.
3. Insert the distance element and the cam by fitting it by the threaded screw.

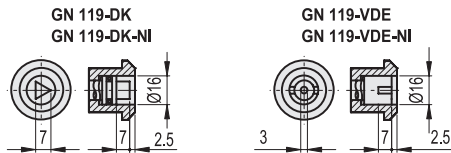
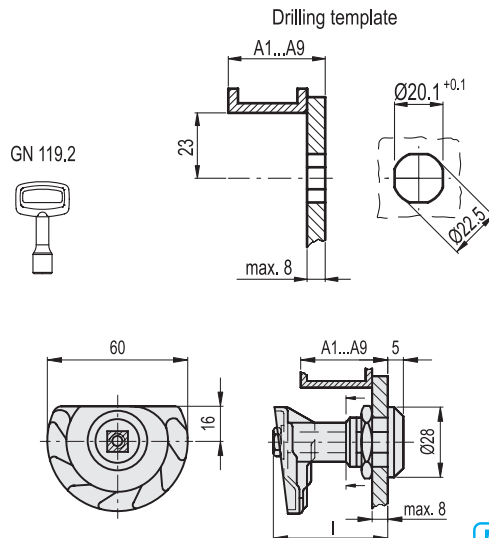

GN 119-DK

Code	Description	A1...A9	l	△
GN.38501	GN 119-DK-A1	17 + 25	28	104
GN.38502	GN 119-DK-A2	22 + 30	33	106
GN.38503	GN 119-DK-A3	27 + 35	38	112
GN.38504	GN 119-DK-A4	32 + 40	43	113
GN.38505	GN 119-DK-A5	37 + 45	48	118
GN.38506	GN 119-DK-A6	42 + 50	53	123
GN.38507	GN 119-DK-A7	47 + 55	58	126
GN.38508	GN 119-DK-A8	52 + 60	63	130
GN.38509	GN 119-DK-A9	57 + 65	68	135

GN 119-DK-NI

Code	Description
GN.38521	GN 119-DK-A1-NI
GN.38522	GN 119-DK-A2-NI
GN.38523	GN 119-DK-A3-NI
GN.38524	GN 119-DK-A4-NI
GN.38525	GN 119-DK-A5-NI
GN.38526	GN 119-DK-A6-NI
GN.38527	GN 119-DK-A7-NI
GN.38528	GN 119-DK-A8-NI
GN.38529	GN 119-DK-A9-NI

GN 119-VDE

Code	Description	A1...A9	l	△
GN.38651	GN 119-VDE-A1	17 + 25	28	104
GN.38652	GN 119-VDE-A2	22 + 30	33	106
GN.38653	GN 119-VDE-A3	27 + 35	38	112
GN.38654	GN 119-VDE-A4	32 + 40	43	113
GN.38655	GN 119-VDE-A5	37 + 45	48	118
GN.38656	GN 119-VDE-A6	42 + 50	53	123
GN.38657	GN 119-VDE-A7	47 + 55	58	126
GN.38658	GN 119-VDE-A8	52 + 60	63	130
GN.38659	GN 119-VDE-A9	57 + 65	68	135

GN 119-VDE-NI

Code	Description
GN.38671	GN 119-VDE-A1-NI
GN.38672	GN 119-VDE-A2-NI
GN.38673	GN 119-VDE-A3-NI
GN.38674	GN 119-VDE-A4-NI
GN.38675	GN 119-VDE-A5-NI
GN.38676	GN 119-VDE-A6-NI
GN.38677	GN 119-VDE-A7-NI
GN.38678	GN 119-VDE-A8-NI
GN.38679	GN 119-VDE-A9-NI

